

Duration: 3 hours

9/06/25

Total: 80 Marks

Note :

- Question No.1 is compulsory.
- Solve ANY THREE questions from the remaining five questions.
- Figure to the right indicates full marks.
- Assume suitable data wherever required, but justify the same.
- Take $g = 9.81 \text{ m/s}^2$.

Q.1 Solve ANY FOUR questions from the following. (Each question carries 5 marks). 20

a) Determine the mass m for the equilibrium of the 5 kg block as shown in the figure.

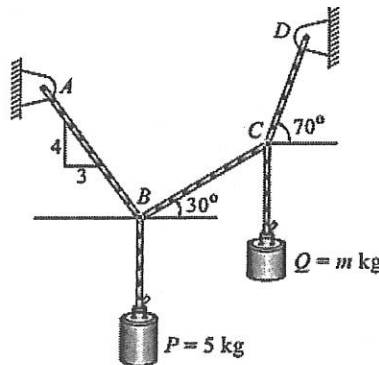

- b) Define the Varignon's theorem and write the significance of Varignon's theorem.
- c) Acceleration of a particle moving along a straight line is represented by the relation $a = t^3 - 2t^2 + 7$. At $t = 1$ second, velocity of the particle is 3.58 m/s and displacement is 9.39 m. Determine the velocity and displacement at $t = 2$ seconds.
- d) State the properties of Instantaneous Centre of Rotation .
- e) Determine the centroid of the given area.

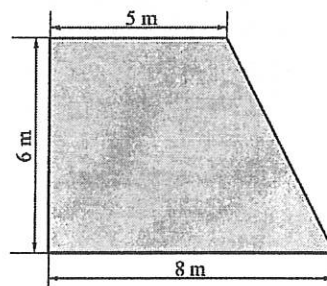

Q.2 a) Two identical rollers of mass 50kg are supported as shown in figure. To maintain the equilibrium, Determine the support reactions assuming all smooth surfaces. 8

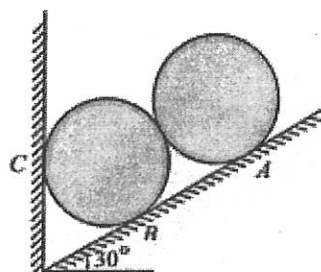

- b) Calculate the resultant of the given force system and locate it with respect to the point of action of 200 N force. 6

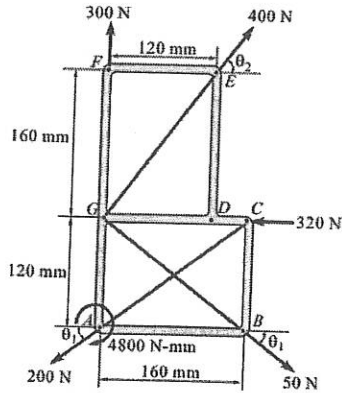

- c) Determine the "x" and "y" coordinates of the Centroid for the shaded area shown. 6

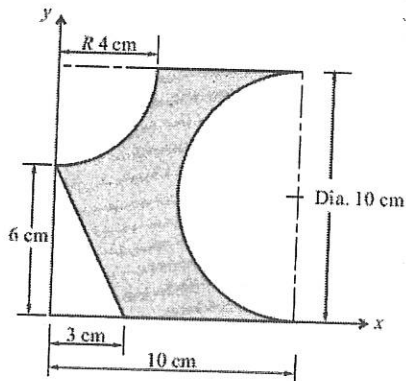

- Q.3 a) A ball is thrown with a speed of 12 m/s at an angle of 60° with a building strikes the ground 11.3 m horizontally from the foot of the building. Determine the height of the building. 8

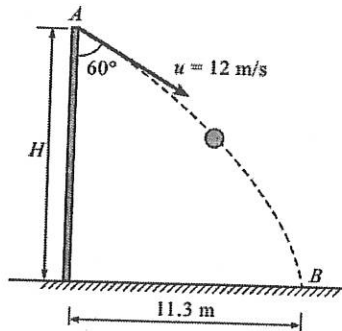

- b) A block of 800 N is placed on an inclined surface. Determine the force P required to prevent the sliding of the block down the plane if the coefficient of friction between the block and surface is 0.35. 6

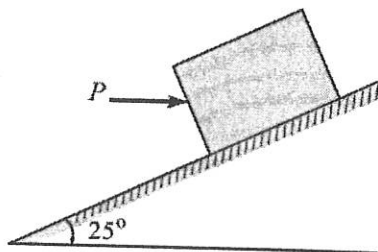

- c) A point moving along a path $y=x^2/3$ with a constant speed of 8m/s. What are the x and y components of its velocity when $x=3m$? Also, find the radius of curvature and acceleration. 6

- Q4 a) A collar of mass 1kg is attached to spring and slides without friction along a circular rod which lies in a horizontal plane. The spring is undeformed when the collar is at B knowing that the collar is passing through point D with a speed of 1.8 m/s Determine the speed of collar when it passes through point C and B. Take stiffness of the spring, $k=250N/m$, Radius of the circular path =300mm and distance $OA=125mm$. 8

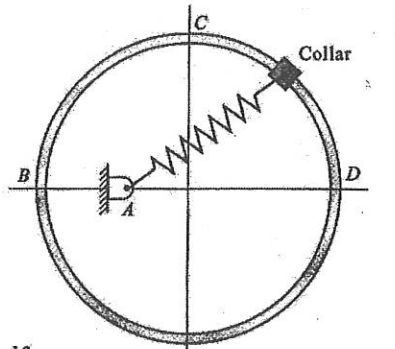

- b) At the instant shown, locate the ICR and determine the angular velocity of rod BC and the velocity of the piston C. 6

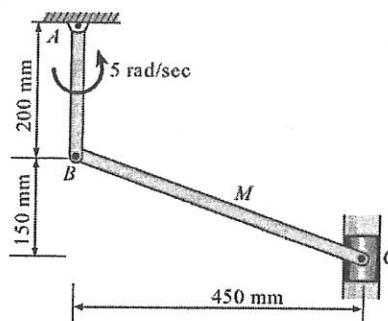

- c) A ball is thrown vertically down on a smooth horizontal floor with a velocity of 10 m/s from which it bounces to a height of 3 m. If the coefficient of restitution is 0.7. Find the maximum height it can reach after hitting the ground. 6

- Q5. a) A car moves along a straight road such that its acceleration time motion is described by the graph shown in fig. construct v-t and s-t graphs and determine the maximum speed and maximum distance covered. 8

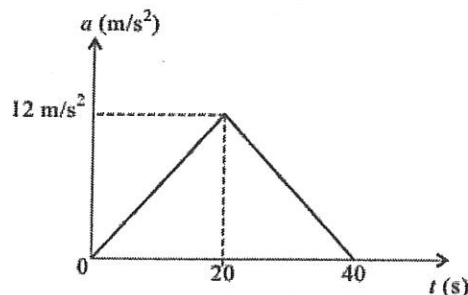

- b) The system shown in fig. is released from rest. What is the height lost by bodies A, B and C in 2 sec. Take coefficient of kinetic friction at rubbing surfaces as 0.4. Find tension in each rope. Assume pulleys to be frictionless. 6

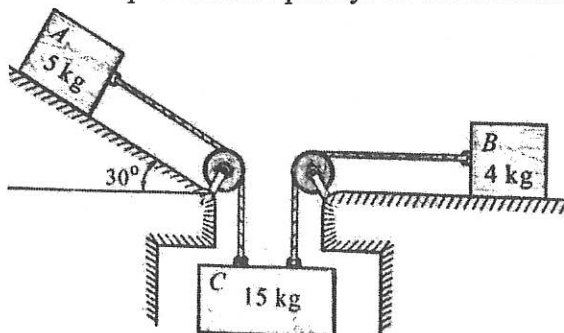

- c) A force $F = 100\text{ N}$ acts at a point A $(-2, 3, 5)\text{ m}$ has its line of action passing through point B $(10, 3, 4)\text{ m}$. Calculate moment of the force about the origin. 6
- Q6 a) A beam is loaded and supported as shown in figure. Find the support reactions at support A and B. 8

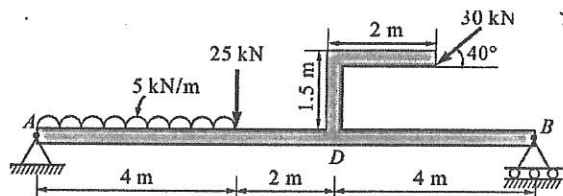

- b) Block A weighs 40 kN and the block B weighs 60 kN. The coefficient of friction between A and B is 0.3 and between B and the floor is 0.25. Determine the value of "P" for holding the system in equilibrium. 6

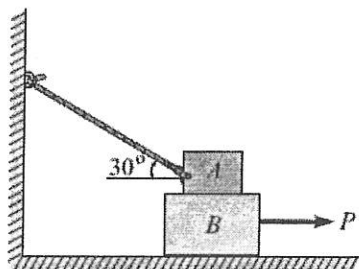

- c) A rectangular plate weighing 500 N is suspended in the horizontal plane using three cables. Find the tension in each cable. 6

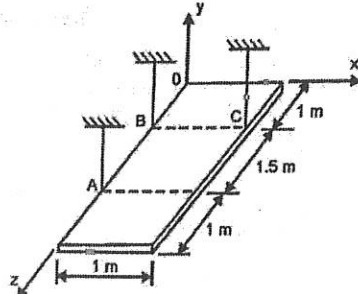

-----XX-----XX-----XX-----